

MOOG

Standard Cartridge Valves – 2/2 Way Series NG16 – NG100

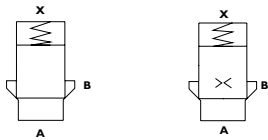
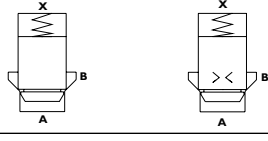
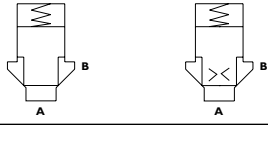
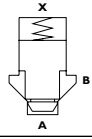
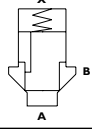
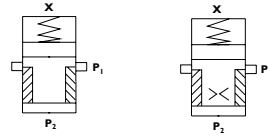

Designation	Symbol	Page
General Description and Operating Principle		4
Specifications and Characteristic Parameters		5
Typical Characteristic Curves		6-7
Standard Models 2-way Cartridge for Pressure Control without Damping		8
Standard Models 2-way Cartridge for Pressure Control with Damping		9
Standard Models 2-way Cartridge for Direction and Flow Control without Damping		10
Standard Models 2-way Cartridge for Direction and Flow with Damping		11
Standard Models 2-way Cartridge for Check Valve		12
Standard Models 2-way Cartridge for Pressure Reducing and Compensator		13
Typical Orifice Characteristics		14
Dimensions		15
Ordering Information and Spare Parts		16-17

General Description and Operating Principle

General Description

Cartridge valves, also known as 2/2-way valves or logic valves, conform to DIN 24342 and ISO 7368 standards. They have two operational ports A and B. The flow path between these two connections is controlled hydraulically by a pilot pressure applied to X.

Depending on the control input, cartridge valves can be used as:

- Directional Control Valves (start, stop, directional control)
- Pressure Control Valves
(pressure relief, pressure control, pressure sequence and unloading function)
- Check Valves
(check valve function and pilot operated check valve function)
- Flow Control Valves

The preferred mode of mounting is the manifold block, which can be equipped with several valves depending on the hydraulic circuit for the specific application. Each valve is connected to each other in the manifold block.

The Moog manifold systems product line contains valves of nominal bores 16, 25, 32, 40, 50, 63, 80 and 100 as per DIN 24342, for flows up to 10,000 lpm. Moreover, Moog offers cover plates and pilot valves for a wide variety of functions.

Operating Principle

Cartridge valves have two working connections A and B, where the main flow is hydraulically operated by a controlling pressure applied to the connection X. The basic cartridge valve includes a valve poppet and sleeve which is normally held in the closed position by a spring. The poppet valve has a seated cone, giving a leakage free (dependent upon pilot control) condition across the two ports. The closing spring is retained by the control cover which encloses the cartridge valve and provides pilot connections from the X port. Various types of pilot control can be mounted either to the control cover or to an adjacent manifold face to provide direct control of the cartridge valve.

The effective areas of the basic element are A_A , A_B and A_X . Pilot oil can be taken from port A, B or both A and B (with a shuttle valve) or an external source. Hydraulic fluid can flow through the 2-way cartridge valve from A→B or B→A.

A pilot valve can be used to directly control the switching function of the cartridge valve, either between two extreme positions, open or closed, or in any number of intermediate positions. The exact position of the valve cone depends on the ratio of control surface A_X , to the pressures acting from the working connections A and B on the seating surface of A_A and the annular area of A_B .

If the valve cone is open, by reducing the pressure seen at X, then flow can move from A and B or vice-versa. By applying a control pressure at X, the working connections A to B are shut off as the valve cone is closed by the seat mounting. If there is a pressure difference between connection B and pilot connection X, as a result of clearance tolerance between the cone and sleeve, then leakage can be eliminated by using a leakproof seat valve and hooking up the pilot connection X to the working connection B. If the desired function does not permit such a switching operation, a cartridge valve with an additional sealing surface can be used to seal the connections A, B and X from each other.

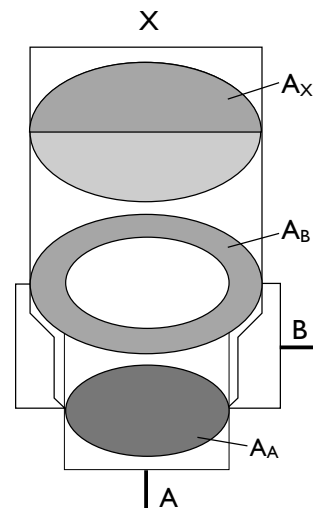
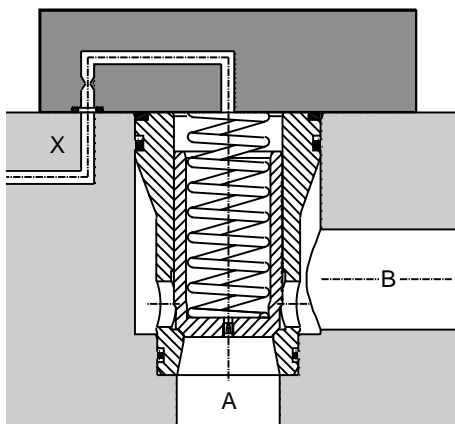

General Data	Value	Unit	Specifications
Designation and Symbol	—	—	2-way Seat Valve (Cartridge)
Mode of Construction	—	—	Pilot Operated Seat Valve
Manner of Mounting	—	—	Manifold Cartridge Mounting
Branch Circuit Connection	—	—	Drilling in the Manifold
Mounting Dimensions	—	—	See Mounting Dimensions Page 15
Mounting Position	—	mm	Any
Flow Direction	—	—	See Cone Types Pages 6-7
Ambient Temperature Range	min.	°F [°C]	-13° [-25°]
	max.	°F [°C]	+140° [+60°]
Working Pressure			
Inlet	min.	psi [bar]	0 [0]
	max.	psi [bar]	5075 [350]
Outlet	min.	psi [bar]	0 [0]
	max.	psi [bar]	5075 [350]
Temperature Range	min.	°F [°C]	-13° [-25°]
	max.	°F [°C]	+176° [+80°]
Viscosity Range	min.	mm ² ·s ⁻¹ [cSt]	2.8
	max.	mm ² ·s ⁻¹ [cSt]	380
Operational Viscosity	Vn	mm ² ·s ⁻¹ [cSt]	35
Orifice Thread in Cone K99	—	—	M5 M5 M6 M6 M8 M8 M8 M8
Pilot Volume (B, C & R Cones)	—	cu. in	.07 .27 .62 1.18 3.12 6.17 13.73 20.28
	—	[cc]	[1.18] [4.4] [10.13] [19.3] [50.9] [101.5] [187.8] [331.42]
Pilot Volume (A&D Cones)	—	cu. in	.07 .25 .61 1.17 2.94 5.66 10.55 21.21
	—	[cc]	[1.19] [4.03] [9.97] [19.23] [48.47] [92.35] [173.06] [346.86]

Characteristic Parameters

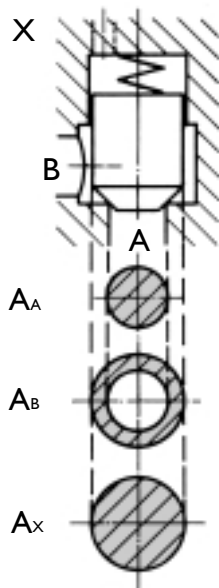

Reference Surface A _A									
	NG16	NG25	NG32	NG40	NG50	NG63	NG80	NG100	
Cones B, C and R									
Stroke in [mm]	0.24 [6]	0.48 [12]	0.55 [14]	0.59 [15]	0.79 [20]	0.94 [24]	1.20 [30.5]	1.44 [36.5]	
A _A in ² [mm ²]	.19 [123]	.35 [227]	.70 [452]	1.25 [804]	2.47 [1590]	4.10 [2642]	5.96 [3848]	8.80 [5675]	
A _A (Ref)	1	1	1	1	1	1	1	1	
A _B	0.6	0.6	0.6	0.6	0.6	0.6	0.6	0.6	
A _X	1.6	1.6	1.6	1.6	1.6	1.6	1.6	1.6	
Cones A and D									
Stroke in [mm]	0.23 [5.9]	0.42 [10.6]	.55 [14.1]	.60 [15.3]	.80 [20.4]	.95 [24]	1.20 [30.5]	1.44 [36.5]	
A _A in ² [mm ²]	.31 [201]	.59 [380]	1.10 [707]	1.95 [1257]	3.68 [2376]	5.96 [3848]	8.79 [5674]	14.73 [9503]	
A _A (Ref)	1	1	1	1	1	1	1	1	
A _B	/	/	/	/	/	/	/	/	
A _X	1	1	1	1	1	1	1	1	
Cone K									
Stroke in [mm]	.24 [6.0]	.24 [6.0]	.32 [8.0]	.43 [11.0]					
A _A in ² [mm ²]	.31 [201]	.59 [380]	1.10 [707]	1.67 [1075]					
A _A (Ref)	1	1	1	1					
A _B	/	/	/	/					
A _X	1	1	1	1					

Performance Data

Pressure Control Function

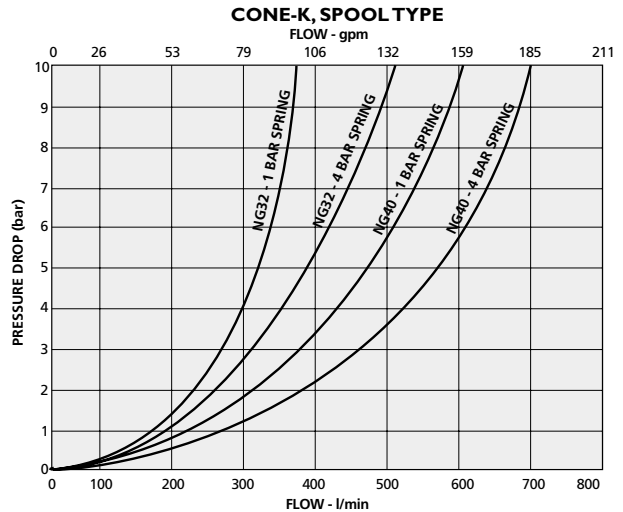
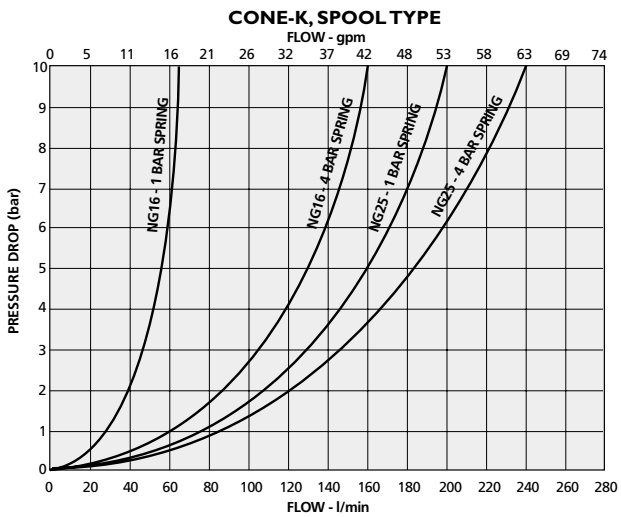
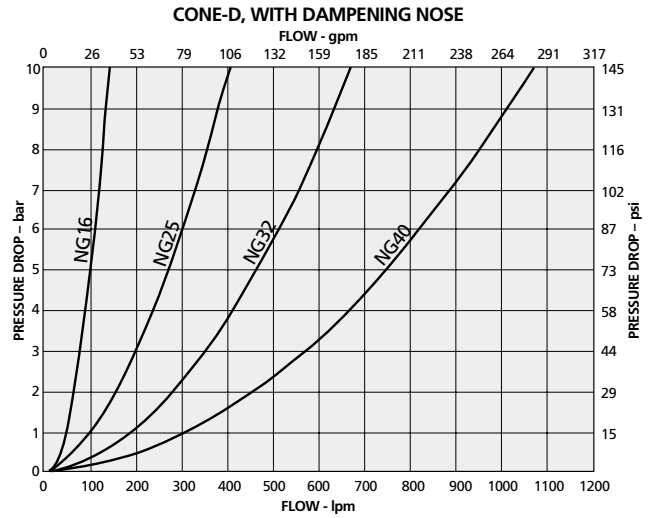
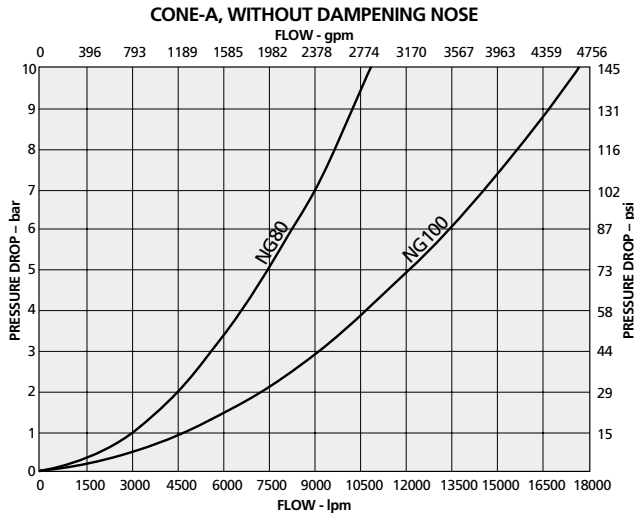
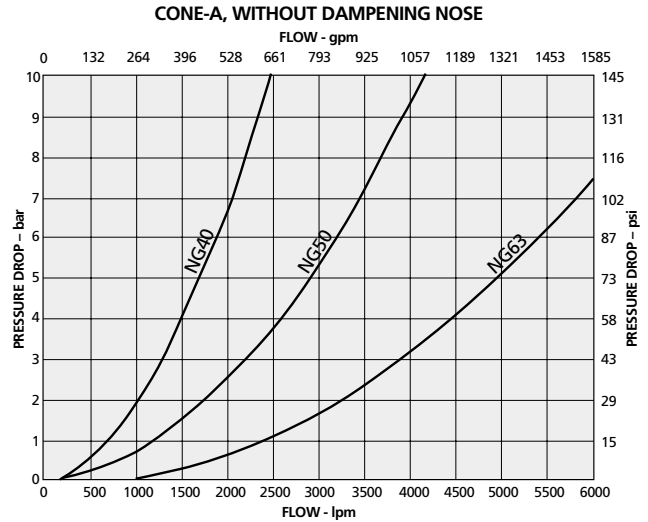
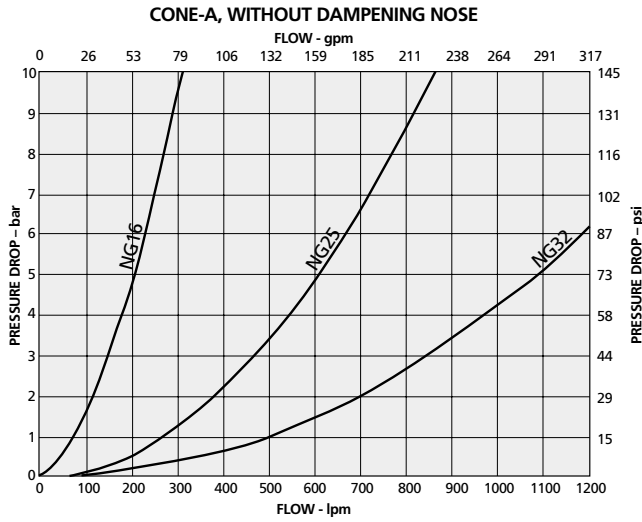

Flow Direction and Check Functions

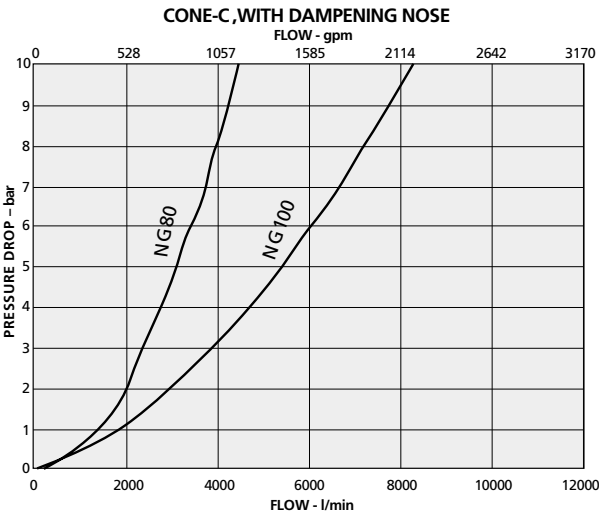
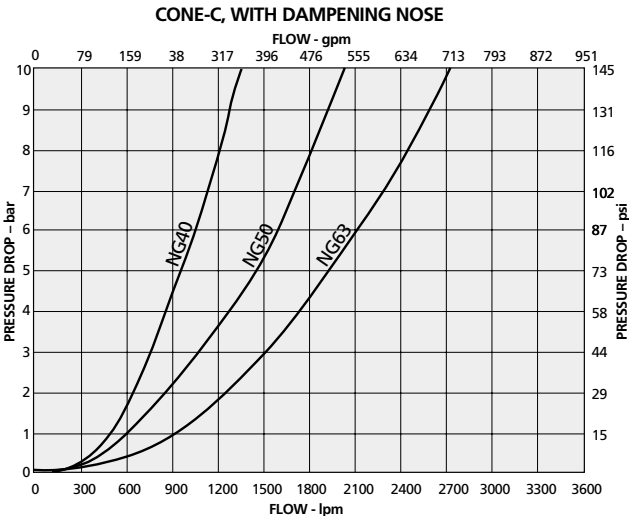
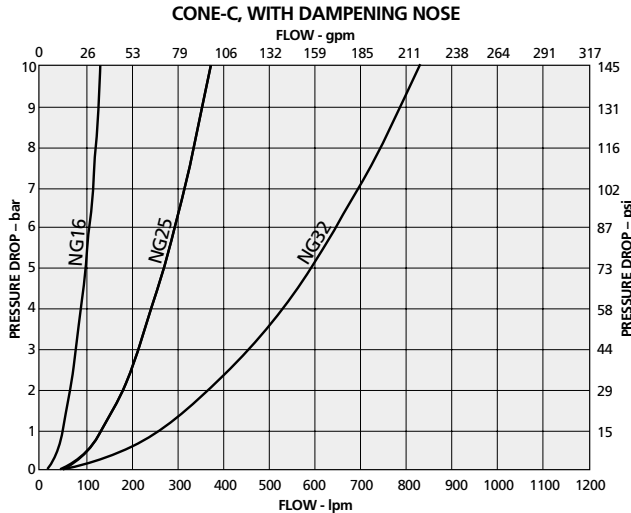
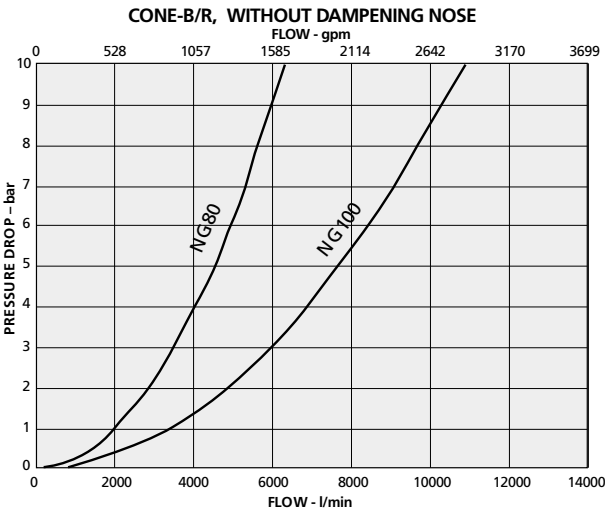
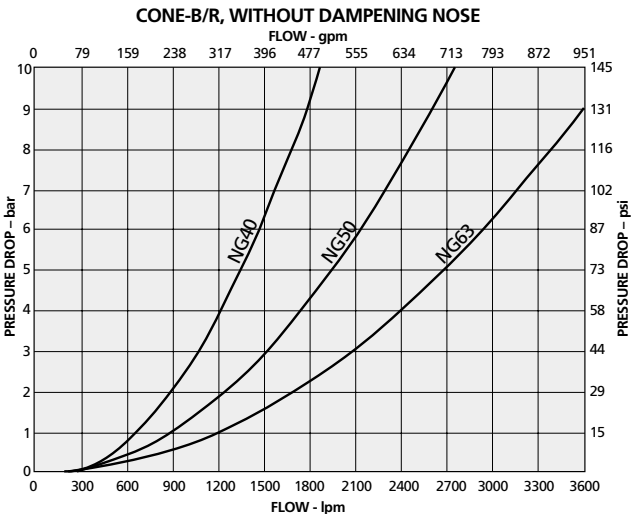
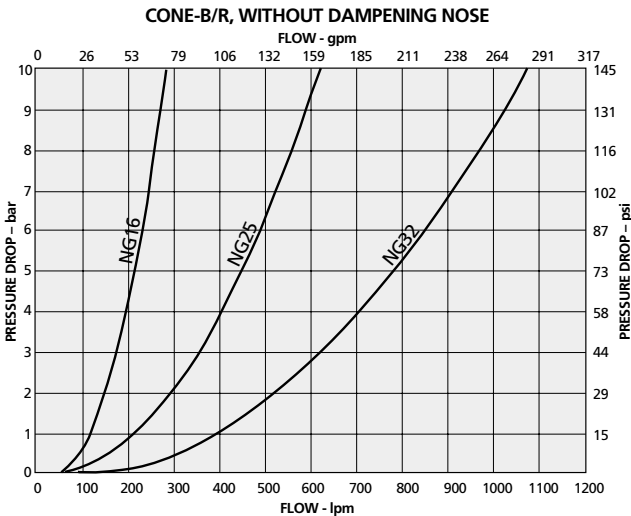

Standard Models

Pressure Control (without dampening nose); area ratio = 1:1
Flow Direction A → B

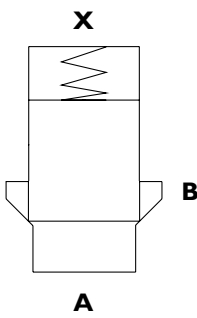
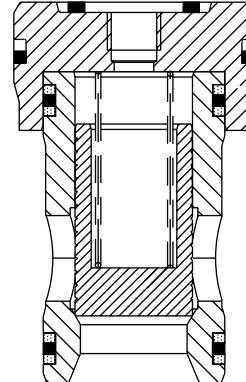
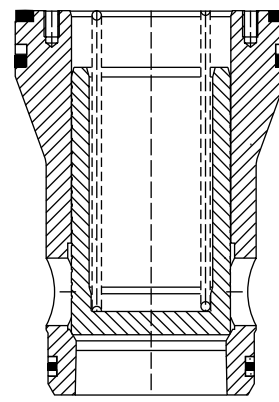
Symbol	Function	Size NG (mm)	Weight lb [kg]	Spring Rating psi [bar]	Part Designation	Part Number	
		16	.44 [0.2]	4.4 [0.3] 14.5 [1.0] 29.0 [2.0] 58.0 [4.0]	M-CEE16B6AP/KOB;DG I5 M-CEE16B6AS/KOB;DG I5 M-CEE16B6AT/KOB;DG I5 M-CEE16B6AU/KOB;DG I5	XCB11483-000-00 XCB11276-000-00 XCB11277-000-00 XCB11278-000-00	
		25	0.9 [0.4]	4.4 [0.3] 14.5 [1.0] 29.0 [2.0] 58.0 [4.0]	M-CEE25B6AP/KOB;DG I5 M-CEE25B6AS/KOB;DG I5 M-CEE25B6AT/KOB;DG I5 M-CEE25B6AU/KOB;DG I5	XCB11378-000-00 XCB11273-000-00 XCB11274-000-00 XCB11275-000-00	
		32	2.0 [0.9]	4.4 [0.3] 14.5 [1.0] 29.0 [2.0] 58.0 [4.0]	M-CEE32B6AP/KOB;DG I5 M-CEE32B6AS/KOB;DG I5 M-CEE32B6AT/KOB;DG I5 M-CEE32B6AU/KOB;DG I5	XCB11484-000-00 XCB11290-000-00 XCB11291-000-00 XCB11292-000-00	
			40	4.0 [1.8]	4.4 [0.3] 14.5 [1.0] 29.0 [2.0] 58.0 [4.0]	M-CEE40B6AP/KOB;DG I5 M-CEE40B6AS/KOB;DG I5 M-CEE40B6AT/KOB;DG I5 M-CEE40B6AU/KOB;DG I5	XCB11485-000-00 XCB11295-000-00 XCB11296-000-00 XCB11297-000-00
			50	7.0 [3.2]	4.4 [0.3] 14.5 [1.0] 29.0 [2.0] 58.0 [4.0]	M-CEE50B6AP/KOB;DG I5 M-CEE50B6AS/KOB;DG I5 M-CEE50B6AT/KOB;DG I5 M-CEE50B6AU/KOB;DG I5	XCB11486-000-00 XCB11306-000-00 XCB11307-000-00 XCB11308-000-00
			63	15.2 [6.9]	4.4 [0.3] 14.5 [1.0] 29.0 [2.0] 58.0 [4.0]	M-CEE63B6AP/KOB;DG I5 M-CEE63B6AS/KOB;DG I5 M-CEE63B6AT/KOB;DG I5 M-CEE63B6AU/KOB;DG I5	XCB11487-000-00 XCB11309-000-00 XCB11310-000-00 XCB11311-000-00
	80		26.5 [12]	4.4 [0.3] 14.5 [1.0] 29.0 [2.0] 58.0 [4.0]	M-CEE80B6AP/KOB;DG I5 M-CEE80B6AS/KOB;DG I5 M-CEE80B6AT/KOB;DG I5 M-CEE80B6AU/KOB;DG I5	XCB11488-000-00 XCB11312-000-00 XCB11313-000-00 XCB11314-000-00	
	100		52.8 [24]	4.4 [0.3] 14.5 [1.0] 29.0 [2.0] 58.0 [4.0]	M-CEE100B6AP/KOB;DG I5 M-CEE100B6AS/KOB;DG I5 M-CEE100B6AT/KOB;DG I5 M-CEE100B6AU/KOB;DG I5	XCB11489-000-00 XCB11429-000-00 XCB11430-000-00 XCB11431-000-00	

Pressure Control (with dampening nose); area ratio = 1:1
Flow Direction A → B

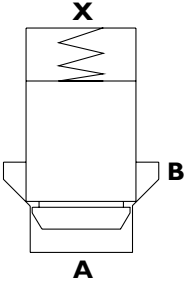
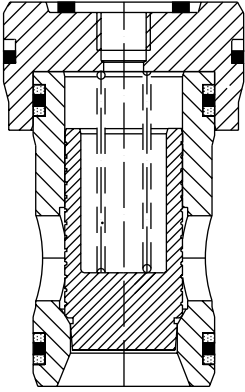
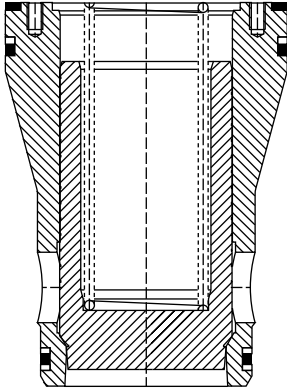
Symbol	Function	Size NG (mm)	Weight lb [kg]	Spring Rating psi [bar]	Part Designation	Part Number
		16	.44 [0.2]	4.4 [0.3]	M-CEE16B6DP/KOB;DG15	XCB11490-000-00
				14.5 [1.0]	M-CEE16B6DS/KOB;DG15	XCB11491-000-00
				29.0 [2.0]	M-CEE16B6DT/KOB;DG15	XCB11492-000-00
				58.0 [4.0]	M-CEE16B6DU/KOB;DG15	XCB11493-000-00
		25	0.9 [0.4]	4.4 [0.3]	M-CEE25B6DP/KOB;DG15	XCB11444-000-00
				14.5 [1.0]	M-CEE25B6DS/KOB;DG15	XCB11446-000-00
	32	2.0 [0.9]	29.0 [2.0]	M-CEE25B6DT/KOB;DG15	XCB11447-000-00	
			58.0 [4.0]	M-CEE25B6DU/KOB;DG15	XCB11448-000-00	
			4.4 [0.3]	M-CEE32B6DP/KOB;DG15	XCB11352-000-00	
			14.5 [1.0]	M-CEE32B6DS/KOB;DG15	XCB11354-000-00	
		40	4.0 [1.8]	29.0 [2.0]	M-CEE32B6DT/KOB;DG15	XCB11355-000-00
				58.0 [4.0]	M-CEE32B6DU/KOB;DG15	XCB11356-000-00
		40	4.0 [1.8]	4.4 [0.3]	M-CEE40B6DP/KOB;DG15	XCB11494-000-00
				14.5 [1.0]	M-CEE40B6DS/KOB;DG15	XCB11420-000-00
29.0 [2.0]				M-CEE40B6DT/KOB;DG15	XCB11421-000-00	
58.0 [4.0]				M-CEE40B6DU/KOB;DG15	XCB11422-000-00	
50		7.0 [3.2]	4.4 [0.3]	M-CEE50B6DP/KOB;DG15	XCB11495-000-00	
			14.5 [1.0]	M-CEE50B6DS/KOB;DG15	XCB11496-000-00	
50		7.0 [3.2]	29.0 [2.0]	M-CEE50B6DT/KOB;DG15	XCB11497-000-00	
			58.0 [4.0]	M-CEE50B6DU/KOB;DG15	XCB11498-000-00	
	4.4 [0.3]		M-CEE63B6DP/KOB;DG15	XCB11499-000-00		
	14.5 [1.0]		M-CEE63B6DS/KOB;DG15	XCB11500-000-00		
63	15.2 [6.9]	29.0 [2.0]	M-CEE63B6DT/KOB;DG15	XCB11501-000-00		
		58.0 [4.0]	M-CEE63B6DU/KOB;DG15	XCB11502-000-00		
80	26.5 [12]	4.4 [0.3]	M-CEE80B6DP/KOB;DG15	XCB11503-000-00		
		14.5 [1.0]	M-CEE80B6DS/KOB;DG15	XCB11504-000-00		
		29.0 [2.0]	M-CEE80B6DT/KOB;DG15	XCB11505-000-00		
		58.0 [4.0]	M-CEE80B6DU/KOB;DG15	XCB11506-000-00		
100	52.8 [24]	4.4 [0.3]	M-CEE100B6DP/KOB;DG15	XCB11507-000-00		
		14.5 [1.0]	M-CEE100B6DS/KOB;DG15	XCB11508-000-00		
		29.0 [2.0]	M-CEE100B6DT/KOB;DG15	XCB11509-000-00		
		58.0 [4.0]	M-CEE100B6DU/KOB;DG15	XCB11510-000-00		

Standard Models

Directional Control (without dampening nose); area ratio = 1:1.6
Flow Direction A ↔ B

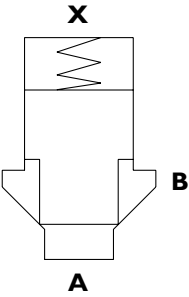
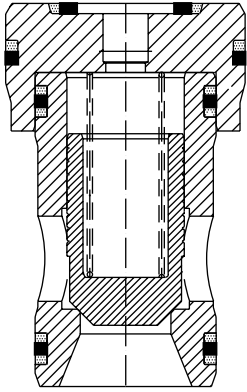
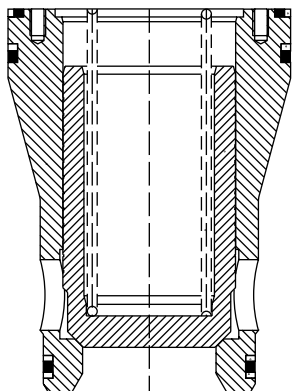
Symbol	Function	Size NG (mm)	Weight lb [kg]	Spring Rating psi [bar]	Part Designation	Part Number
		16	.44 [0.2]	4.4 [0.3] 14.5 [1.0] 29.0 [2.0] 58.0 [4.0]	M-CEE16B6BP/KOB M-CEE16B6BS/KOB M-CEE16B6BT/KOB M-CEE16B6BU/KOB	XCB10170-000-00 XCB10172-000-00 XCB10173-000-00 XCB10174-000-00
		25	0.9 [0.4]	4.4 [0.3] 14.5 [1.0] 29.0 [2.0] 58.0 [4.0]	M-CEE25B6BP/KOB M-CEE25B6BS/KOB M-CEE25B6BT/KOB M-CEE25B6BU/KOB	XCB10198-000-00 XCB10200-000-00 XCB10201-000-00 XCB10202-000-00
		32	2.0 [0.9]	4.4 [0.3] 14.5 [1.0] 29.0 [2.0] 58.0 [4.0]	M-CEE32B6BP/KOB M-CEE32B6BS/KOB M-CEE32B6BT/KOB M-CEE32B6BU/KOB	XCB10226-000-00 XCB10228-000-00 XCB10229-000-00 XCB10230-000-00
		40	4.0 [1.8]	4.4 [0.3] 14.5 [1.0] 29.0 [2.0] 58.0 [4.0]	M-CEE40B6BP/KOB M-CEE40B6BS/KOB M-CEE40B6BT/KOB M-CEE40B6BU/KOB	XCB10253-000-00 XCB10255-000-00 XCB10256-000-00 XCB10257-000-00
		50	7.0 [3.2]	4.4 [0.3] 14.5 [1.0] 29.0 [2.0] 58.0 [4.0]	M-CEE50B6BP/KOB M-CEE50B6BS/KOB M-CEE50B6BT/KOB M-CEE50B6BU/KOB	XCB10277-000-00 XCB10279-000-00 XCB10208-000-00 XCB10281-000-00
		63	15.2 [6.9]	4.4 [0.3] 14.5 [1.0] 29.0 [2.0] 58.0 [4.0]	M-CEE63B6BP/KOB M-CEE63B6BS/KOB M-CEE63B6BT/KOB M-CEE63B6BU/KOB	XCB10297-000-00 XCB10299-000-00 XCB10300-000-00 XCB10301-000-00
		80	26.5 [12]	4.4 [0.3] 14.5 [1.0] 29.0 [2.0] 58.0 [4.0]	M-CEE80B6BP/KOB M-CEE80B6BS/KOB M-CEE80B6BT/KOB M-CEE80B6BU/KOB	XCB10317-000-00 XCB10319-000-00 XCB10320-000-00 XCB10321-000-00
		100	52.8 [24]	4.4 [0.3] 14.5 [1.0] 29.0 [2.0] 58.0 [4.0]	M-CEE100B6BP/KOB M-CEE100B6BS/KOB M-CEE100B6BT/KOB M-CEE100B6BU/KOB	XCB10337-000-00 XCB10339-000-00 XCB10340-000-00 XCB10341-000-00

Directional Control (with dampening nose); area ratio = 1:1.6
Flow Direction A ↔ B

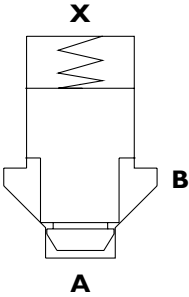
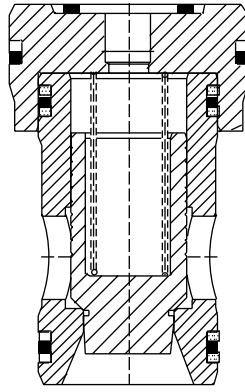
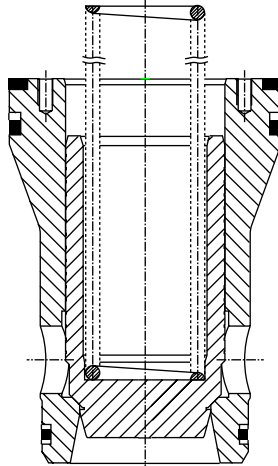
Symbol	Function	Size NG (mm)	Weight lb [kg]	Spring Rating psi [bar]	Part Designation	Part Number	
		16	.44 [0.2]	4.4 [0.3] 14.5 [1.0] 29.0 [2.0] 58.0 [4.0]	M-CEE16B6CP/KOB M-CEE16B6CS/KOB M-CEE16B6CT/KOB M-CEE16B6CU/KOB	XCBI0177-000-00 XCBI0179-000-00 XCBI0180-000-00 XCBI0181-000-00	
		25	0.9 [0.4]	4.4 [0.3] 14.5 [1.0] 29.0 [2.0] 58.0 [4.0]	M-CEE25B6CP/KOB M-CEE25B6CS/KOB M-CEE25B6CT/KOB M-CEE25B6CU/KOB	XCBI0205-000-00 XCBI0207-000-00 XCBI0208-000-00 XCBI0209-000-00	
		32	2.0 [0.9]	4.4 [0.3] 14.5 [1.0] 29.0 [2.0] 58.0 [4.0]	M-CEE32B6CP/KOB M-CEE32B6CS/KOB M-CEE32B6CT/KOB M-CEE32B6CU/KOB	XCBI0233-000-00 XCBI0235-000-00 XCBI0236-000-00 XCBI0237-000-00	
			40	4.0 [1.8]	4.4 [0.3] 14.5 [1.0] 29.0 [2.0] 58.0 [4.0]	M-CEE40B6CP/KOB M-CEE40B6CS/KOB M-CEE40B6CT/KOB M-CEE40B6CU/KOB	XCBI0259-000-00 XCBI0261-000-00 XCBI0262-000-00 XCBI0263-000-00
			50	7.0 [3.2]	4.4 [0.3] 14.5 [1.0] 29.0 [2.0] 58.0 [4.0]	M-CEE50B6CP/KOB M-CEE50B6CS/KOB M-CEE50B6CT/KOB M-CEE50B6CU/KOB	XCBI0282-000-00 XCBI0284-000-00 XCBI0285-000-00 XCBI0286-000-00
			63	15.2 [6.9]	4.4 [0.3] 14.5 [1.0] 29.0 [2.0] 58.0 [4.0]	M-CEE63B6CP/KOB M-CEE63B6CS/KOB M-CEE63B6CT/KOB M-CEE63B6CU/KOB	XCBI0302-000-00 XCBI0304-000-00 XCBI0305-000-00 XCBI0306-000-00
	80		26.5 [12]	4.4 [0.3] 14.5 [1.0] 29.0 [2.0] 58.0 [4.0]	M-CEE80B6CP/KOB M-CEE80B6CS/KOB M-CEE80B6CT/KOB M-CEE80B6CU/KOB	XCBI0332-000-00 XCBI0324-000-00 XCBI0325-000-00 XCBI0326-000-00	
	100		52.8 [24]	4.4 [0.3] 14.5 [1.0] 29.0 [2.0] 58.0 [4.0]	M-CEE100B6CP/KOB M-CEE100B6CS/KOB M-CEE100B6CT/KOB M-CEE100B6CU/KOB	XCBI0342-000-00 XCBI0344-000-00 XCBI0345-000-00 XCBI0346-000-00	

Standard Models

Check Valve; area ratio = 1:1.6
Flow Direction A → B

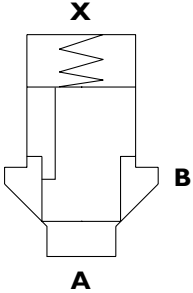
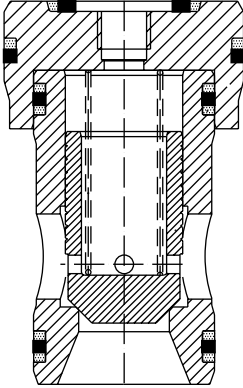
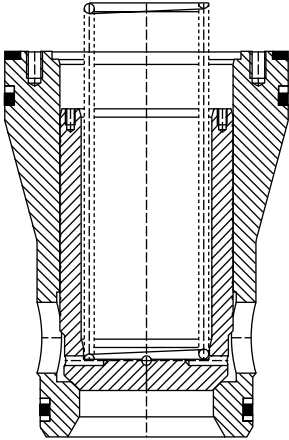
Symbol	Function	Size NG (mm)	Weight lb [kg]	Spring Rating psi [bar]	Part Designation	Part Number
		16	.44 [0.2]	4.4 [0.3] 14.5 [1.0] 29.0 [2.0] 58.0 [4.0]	M-CEE16B6RP M-CEE16B6RS M-CEE16B6RT M-CEE16R6U	XCB10367-000-00 XCB10369-000-00 XCB10370-000-00 XCB10371-000-00
		25	0.9 [0.4]	4.4 [0.3] 14.5 [1.0] 29.0 [2.0] 58.0 [4.0]	M-CEE25B6RP M-CEE25B6RS M-CEE25B6RT M-CEE25B6RU	XCB10402-000-00 XCB10404-000-00 XCB10405-000-00 XCB10406-000-00
		32	2.0 [0.9]	4.4 [0.3] 14.5 [1.0] 29.0 [2.0] 58.0 [4.0]	M-CEE32B6RP M-CEE32B6RS M-CEE32B6RT M-CEE32B6RU	XCB10437-000-00 XCB10439-000-00 XCB10440-000-00 XCB10441-000-00
		40	4.0 [1.8]	4.4 [0.3] 14.5 [1.0] 29.0 [2.0] 58.0 [4.0]	M-CEE40B6RP M-CEE40B6RS M-CEE40B6RT M-CEE40B6RU	XCB10469-000-00 XCB10471-000-00 XCB10472-000-00 XCB10473-000-00
		50	7.0 [3.2]	4.4 [0.3] 14.5 [1.0] 29.0 [2.0] 58.0 [4.0]	M-CEE50B6RP M-CEE50B6RS M-CEE50B6RT M-CEE50B6RU	XCB10497-000-00 XCB10499-000-00 XCB10500-000-00 XCB10501-000-00
		63	15.2 [6.9]	4.4 [0.3] 14.5 [1.0] 29.0 [2.0] 58.0 [4.0]	M-CEE63B6RP M-CEE63B6RS M-CEE63B6RT M-CEE63B6RU	XCB10522-000-00 XCB10524-000-00 XCB10525-000-00 XCB10526-000-00
		80	26.5 [12.0]	4.4 [0.3] 14.5 [1.0] 29.0 [2.0] 58.0 [4.0]	M-CEE80B6RP M-CEE80B6RS M-CEE80B6RT M-CEE80B6RU	XCB10557-000-00 XCB10559-000-00 XCB10560-000-00 XCB10561-000-00
		100	52.8 [24.0]	4.4 [0.3] 14.5 [1.0] 29.0 [2.0] 58.0 [4.0]	M-CEE100B6RP M-CEE100B6RS M-CEE100B6RT M-CEE100B6RU	XCB10572-000-00 XCB10574-000-00 XCB10575-000-00 XCB10576-000-00

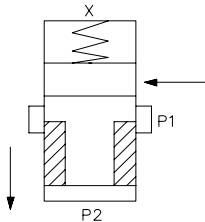
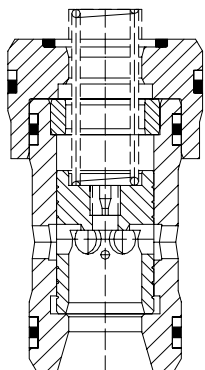
Symbol	Function	Size NG [mm]	Spring Rating bar	Part Designation	Part Number
 <p>Flow only P1=>P2</p>		16	2,0	M-CKE16B6MT/K99	XCBI1082-000-00
			4,0	M-CKE16B6MU/K99	XCBI1083-000-00
		25	2,0	M-CKE25B6MT/K99	XCBI1088-000-00
			4,0	M-CKE25B6MU/K99	XCBI1089-000-00
		32	2,0	M-CKE32B6MT/K99	XCBI1541-000-00
			4,0	M-CKE32B6MU/K99	XCBI1542-000-00
		40	2,0	M-CKE40B6MT/K99	XCBI0965-000-00
			4,0	M-CKE40B6MU/K99	XCBI0966-000-00

These CKE-Cartridge can be ordered only with the below covers ! They are only compatible with these covers !

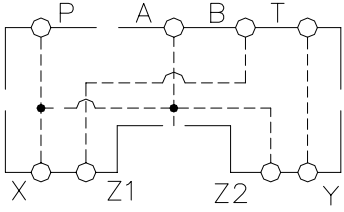
Symbol	Size	Part Designation	Part Number
	16	CCE16B61WDBX06/DM	XEBI6399-000-01
	25	CCE25B61WDBX06/DM	XEBI6042-000-01
	32	CCE32B61WDBX06/DM	XEBI6102-000-01
	40	CCE40B61WDBX06/DM	XEBI3491-000-01

Typical Orifice Characteristics

The function and switching velocity of a cartridge-valve can be influenced by changes in the metering-in and metering-out flow through the pilot lines. This is achieved by changing mounting orifices as required.

The following diagram and table should be used for selecting the correct orifice diameter.

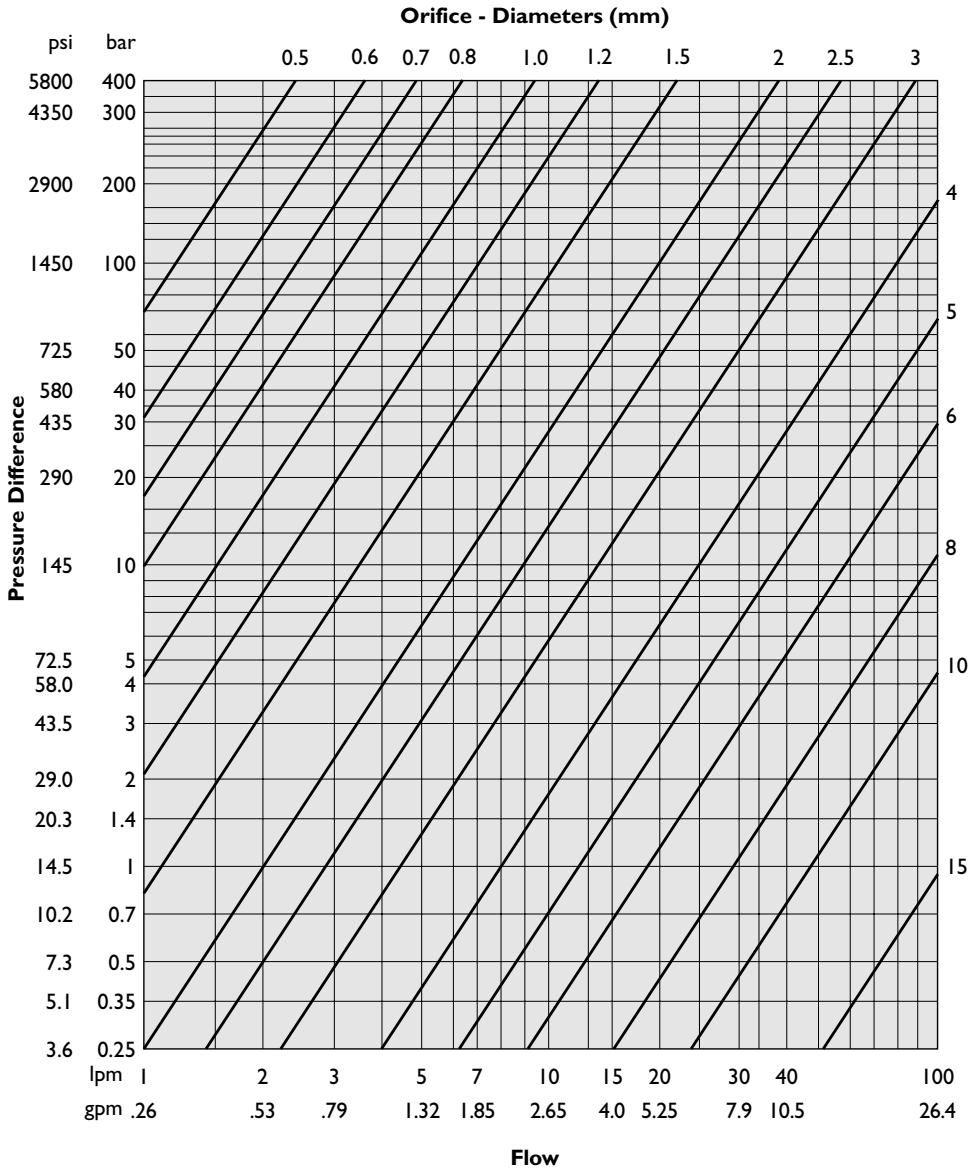

Order Numbers for Orifices

CEE	Orifice Choice	Order Number
	Plug M5x5x0.0	X78490500
	Orifice M5x5x0.6	X78490506
	Orifice M5x5x0.8	X78490508
E16	Orifice M5x5x0.9	X78490509
E25	Orifice M5x5x1.0	X78490510
E32	Orifice M6x6x1.2	X78490612
E40	Orifice M6x6x1.2	X78490612
	Orifice M6x6x1.4	X78490614
	Orifice M6x6x1.5	X78490615
	Orifice M6x6x1.8	X78490618
	Orifice M6x6x2.0	X78490620
	Orifice M6x6x2.4	X78490624
	Plug M8x8x0.0	X78490800
	Orifice M8x8x0.6	X78490806
	Orifice M8x8x0.8	X78490808
	Orifice M8x8x0.9	X78490809
E50	Orifice M8x8x1.0	X78490810
E63	Orifice M8x8x1.1	X78490811
E80	Orifice M8x8x1.2	X78490812
E100	Orifice M8x8x1.5	X78490815
	Orifice M8x8x1.8	X78490818
	Orifice M8x8x2.0	X78490820
	Orifice M8x8x2.5	X78490825
	Orifice M8x8x2.6	X78490826
	Orifice M8x8x3.0	X78490830
	Orifice M8x8x3.5	X78490835

Order example:
Orifice M5x5x0.8 NB16
Order Number: X78490508

Viscosity : 35 mm² · s⁻¹ [cSt]
Oil temperature : 122°F [50°C]

Cavity and Porting Pattern as per DIN 24342

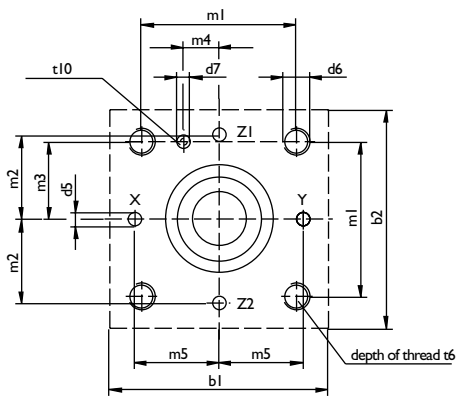
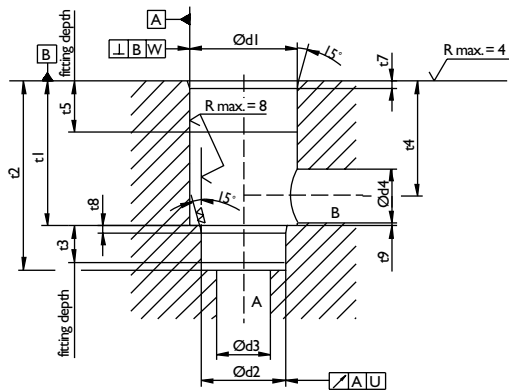

NG16-NG63

Dimensions [mm]	NG16	NG25	NG32	NG40	NG50	NG63
b1	65	85	102	125	140	180
b2	65	85	102	125	140	180
d1 H7	32	45	60	75	90	120
d2 H7	25	34	45	55	68	90
d3	16	25	32	40	50	63
d3 max	17	25	32	43	54	66
d4	16	25	32	40	50	63
d4 max	25	32	40	50	63	80
d5 max	4	6	8	10	10	12
d6	M8	M12	M16	M20	M20	M30
d7 H13	6	6	6	6	8	8
m1 ±0.2	46	58	70	85	100	125
m2 ±0.2	25	33	41	50	58	75
m3 ±0.2	23	29	35	42.5	50	62.5
m4 ±0.2	10.5	16	17	23	30	38
m5 ±0.2	25	33	41	50	58	75
t1 +0.1	43	58	70	87	100	130
t2 +0.1	56	72	85	105	122	155
t3	11	12	13	15	17	20
t4	34	44	52	64	72	95
t4 at d4 max	29.5	40.5	48	59	65.5	86.5
t5	20	30	30	30	35	35
t6	20	25	35	45	45	65
t7	2	2.5	2.5	3	4	4
t8	2	2.5	2.5	3	4	4
t9 cont. dim. min.	0.5	1.0	1.5	2.5	2.5	3
t10 min.	10	10	10	10	10	10
U	0.03	0.03	0.03	0.05	0.05	0.05
W	0.05	0.05	0.1	0.1	0.1	0.2

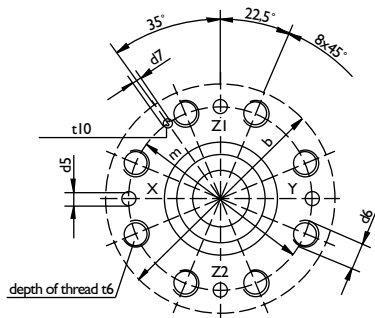

NG80-NG100

Dimensions [mm]	NG80	NG100
b max	250	300
d1 H7	145	180
d2 H7	110	135
d3	80	100
d3 max	82	107
d4	80	100
d4 max	104	120
d5 max	16	20
d6	M24	M30
d7 H	10	10
t1	175	210
t2 +0.2	205	245
t3	25	29
t4	130	155
t4 at d4 max	118	145
t5	40	50
t6	45	55
t7	5	5
t8	5	5
t9 cont. dim. min.	5	5
t10 min.	10	10
m ±0.3	200	245
U	0.05	0.05
W	0.2	0.2

Ordering Information

Poppet Style Cartridge

M — **C** **E** **E** **B** **6** / / /

M	MIXED Fluorocarbon & PU seal
V	Fluorocarbon - SEALS
N	BUNA - N SEALS
S	Special seals on request

Valve Type
C | Cartridge valve

Valve Functions
E | Cartridge without cover

Mounting
E | Manifold mounting

Size	Nominal Bore (NG)
16	NG16
25	NG25
32	NG32
40	NG40
50	NG50
63	NG63
80	NG80
100	NG100

Serial Number

Series
6 | Cartridge mounting dimensions as per DIN 24342

Special Designs

KOB	without orifice drill
K08	Orifice 0.8 mm diameter
K99	without orifice, without plug

Opening Pressure psi [bar]		
	cones B, C, R	cones A, D
Z	n/a	n/a
O	1.5 [0.1]	1.0 [0.07]
P	4.4 [0.3]	2.9 [0.2]
R	7.3 [0.5]	4.4 [0.3]
S	14.5 [1.0]	8.7 [0.6]
T	29.0 [2.0]	17.4 [1.2]
U	58.0 [4.0]	34.8 [2.4]
V	87.0 [6.0]	53.7 [3.7]

Omit for Standard Cartridge
X | With shaft seal on the cone – special

Types of Cones and Sleeves	
A	Cone with ratio $\dagger A_s = A_s$
D	Cone with ratio $\dagger A_s = A_s$ with dampening nose
B	Cone with ratio $\dagger A_s < A_s$
C	Cone with ratio $\dagger A_s < A_s$ with dampening nose
R	Cone with ratio $\dagger A_s < A_s$
\dagger	Surfaces see surface area ratios page 5

Subject to technical changes

(1) Specification in 10th of a mm of the diameter and in the same order as indicated in the hydraulic symbol. Other orifices in plain language.

Spare Parts

NG16 – NG32

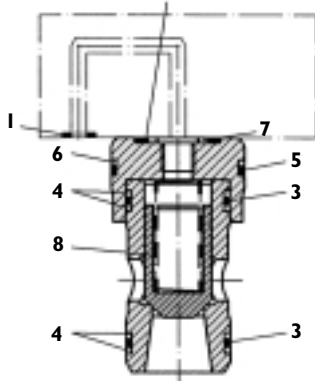

NG40 – NG100

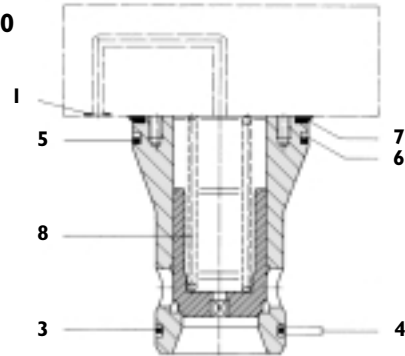

Pos.	Designation	Order Number									
			NG16	NG25	NG32	NG40	NG50	NG63	NG80	NG100	
1	O-Ring 80 Shore	X980-	02010	02012	02013	02112	02112	02116	02215	02220	
	Seal Kit for Cartridge	XEB	12229	12230	12231	12232	12233	12234	12235	12236	
2	O-Ring 80 Shore	X980-	02015	02118	02118	—	—	—	—	—	
3	O-Ring 80 Shore	X980-	02020	02122	02222	02225	02229	02338	02344	02427	
4	Back-Up Ring	X780-	08020	18122	18222	18225	18229	18338	18344	18427	
5	O-Ring 80 Shore	X983-	02024	02129	02227	02231	02338	02347	02430	02439	
6	Back-Up Ring	X780-	18024	18129	08227	18231	18338	08348	08431	18439	
7	Back-Up Ring	X783-	00138	00009	00009	—	—	—	—	—	
7	Axial Seal	X783-	—	—	—	00195	00182	00179	00184	00194	
Springs											
8	Spring O 1.5 psi [-0.1 bar]	XEF	10003	10010	10245	—	—	—	—	—	
8	Spring P 4.4 psi [-0.3 bar]	XEF	10004	10011	10244	10107	10035	10042	10049	10056	
8	Spring R 7.3 psi [-0.5 bar]	XEF	10005	10012	10239	10248	10036	10043	10050	10057	
8	Spring S 14.5 psi [-1.0 bar]	XEF	10006	10013	10138	10106	10037	10044	10051	10058	
8	Spring T 29.0 psi [-2.0 bar]	XEF	10007	10014	10140	10294	10038	10045	10052	10059	
8	Spring U 58.0 psi [-4.0 bar]	XEF	10008	10015	10170	10104	10173	10172	10052	10059	
8	Spring V 87.0 psi [-6.0 bar]	XEF	10009	10016**	10171	10249	—	—	—	—	

** Not possible with stroke limiter IH type cover.

Order example:
O-Ring Pos.3 for NG32
Order number: X98002222

Spring 29.0 psi [2.0 bar] Pos. 8 for NG32
Order number: XEF10140

Spool Type Cartridge

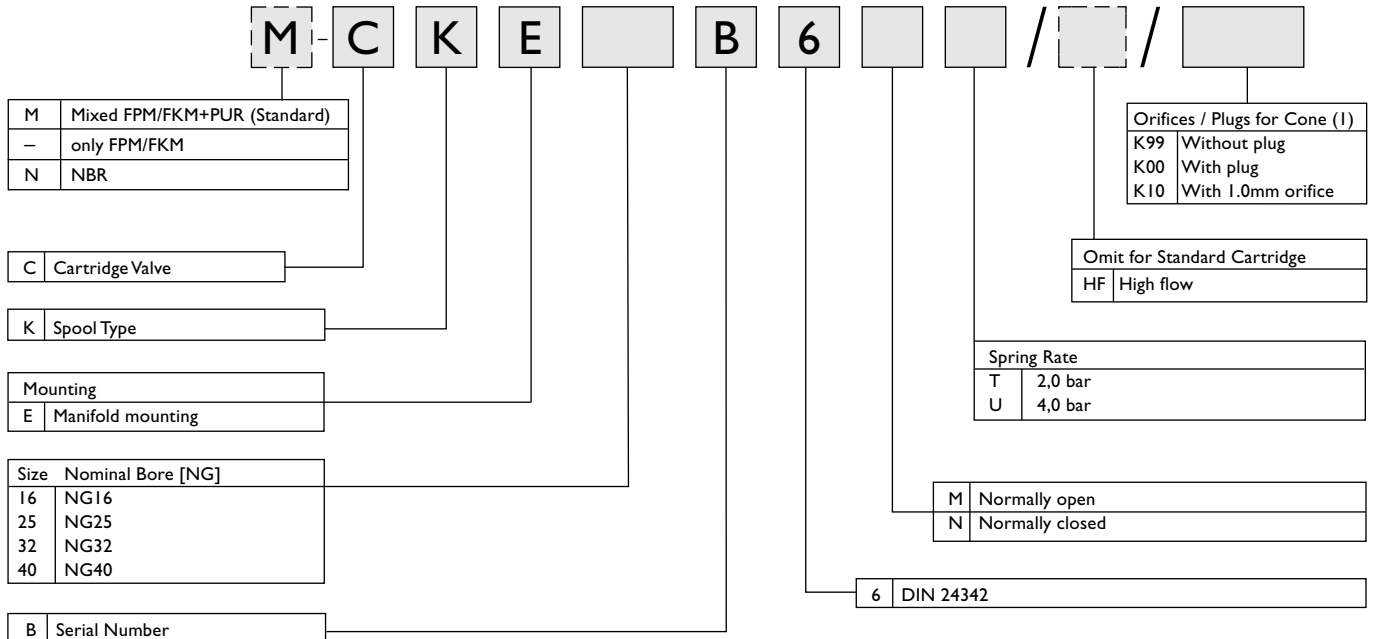

Note: Spool cartridges require use of special covers.
Standard covers cannot be used with these types of cartridges.
Consult applications engineering for more information.

Spare Parts

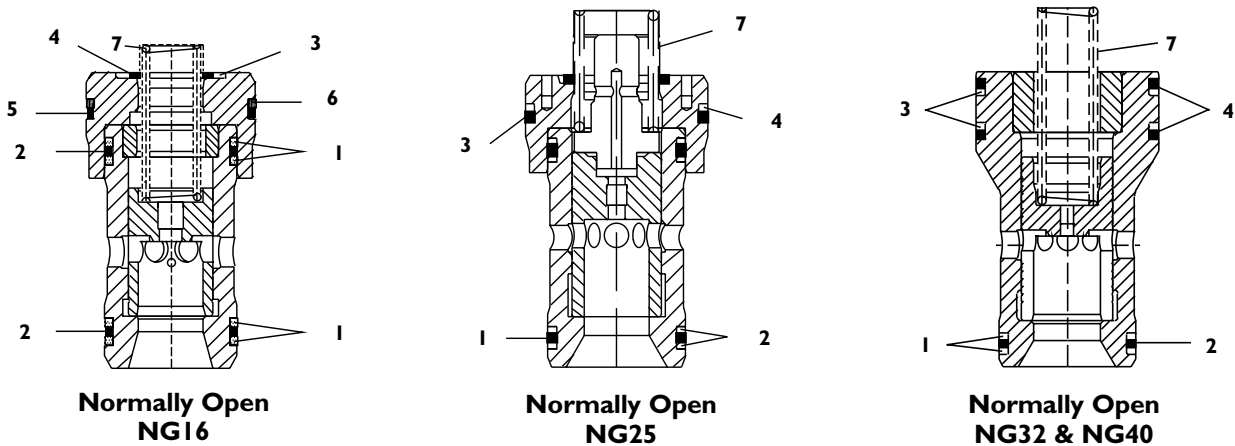

Pos.	Designation	Order Number			
		Normally Open Type			
		NG16	NG25	NG32	NG40
1	Back-Up Ring	X780-08020	X780-18122	X780-18222	X780-18225
2	O-Ring	X980-02020	X980-02122	X980-02222	X980-02225
3	Axial Seal	XE16367	XE14450	-	-
3	Back-Up Ring	-	-	X780-08227	X78018231
4	O-Ring	-	-	X980-02227	X980-02231
5	O-Ring	X980-02024	X980-02129	-	-
6	Back-Up Ring	X780-18024	X780-18129	-	-
7	Springs				
7a	2,0 bar	XEF10237	XEF10014	XEF10140	XEF10105
7b	4,0 bar	XEF10109	XEF10015	XEF10191	XEF10104
8	Orifice	CONSULT FACTORY			



Argentina
Australia
Austria
Brazil
China
Finland
France
Germany
India



Ireland
Italy
Japan
Korea
Luxembourg
Norway
Russia
Singapore
Spain
Sweden
United Kingdom
USA

MOOG

Moog Industrial Controls Division
East Aurora, NY 14052-0018
Telephone: 716/652-2000
Fax: 716/687-7910
Toll Free: 1-800-272-MOOG
www.moog.com